

(12) INTERNATIONAL APPLICATION PUBLISHED UNDER THE PATENT COOPERATION TREATY (PCT)

(19) World Intellectual Property Organization  
International Bureau



(43) International Publication Date  
31 July 2003 (31.07.2003)

PCT

(10) International Publication Number  
WO 03/062729 A1

(51) International Patent Classification<sup>7</sup>: F28D 17/00

SG, SK, SL, TJ, TM, TN, TR, TT, TZ, UA, UG, US, UZ, VC, VN, YU, ZA, ZM, ZW.

(21) International Application Number: PCT/US03/00998

(22) International Filing Date: 10 January 2003 (10.01.2003)

(84) Designated States (*regional*): ARIPO patent (GH, GM, KE, LS, MW, MZ, SD, SL, SZ, TZ, UG, ZM, ZW), Eurasian patent (AM, AZ, BY, KG, KZ, MD, RU, TJ, TM), European patent (AT, BE, BG, CH, CY, CZ, DE, DK, EE, ES, FI, FR, GB, GR, HU, IE, IT, LU, MC, NL, PT, SE, SI, SK, TR), OAPI patent (BF, BJ, CF, CG, CI, CM, GA, GN, GQ, GW, ML, MR, NE, SN, TD, TG).

(25) Filing Language: English

(26) Publication Language: English

(30) Priority Data:  
60/352,097 23 January 2002 (23.01.2002) US

Declaration under Rule 4.17:  
— of inventorship (Rule 4.17(iv)) for US only

(71) Applicant and

(72) Inventor: D'SOUZA, Melanius [US/US]; 1718 Avenida Entrada, San Dimas, CA 91773-4314 (US).

Published:  
— with international search report  
— before the expiration of the time limit for amending the claims and to be republished in the event of receipt of amendments

(81) Designated States (*national*): AE, AG, AL, AM, AT, AU, AZ, BA, BB, BG, BR, BY, BZ, CA, CH, CN, CO, CR, CU, CZ, DE, DK, DM, DZ, EC, EE, ES, FI, GB, GD, GE, GH, GM, HR, HU, ID, IL, IN, IS, JP, KE, KG, KP, KR, KZ, LC, LK, LR, LS, LT, LU, LV, MA, MD, MG, MK, MN, MW, MX, MZ, NO, NZ, OM, PH, PL, PT, RO, RU, SC, SD, SE,

For two-letter codes and other abbreviations, refer to the "Guidance Notes on Codes and Abbreviations" appearing at the beginning of each regular issue of the PCT Gazette.

(54) Title: MODULAR REGENERATIVE HEAT EXCHANGER SYSTEM

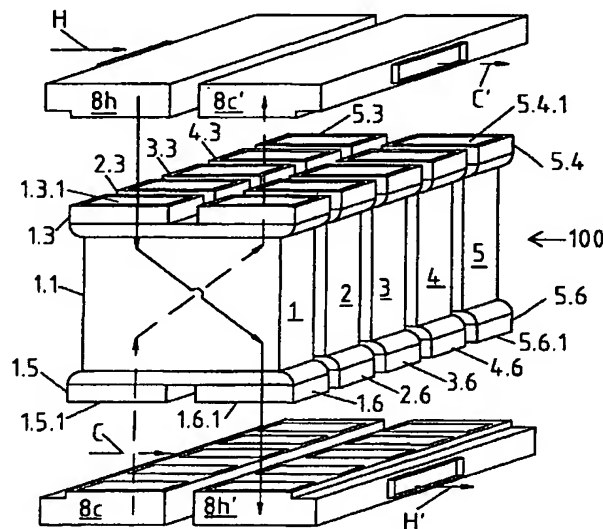

(57) Abstract: A plurality of independently operable regenerative heat exchanger modules (1-5) are provided to regeneratively transfer heat from a hot gas to a cold gas. The regenerative heat exchanger modules are connected to a regenerative heat exchanger system controller (1p-5p) which staggers the operation of each regenerative heat exchanger module to simulate the operation of a rotary regenerative heat exchanger. The regenerative heat exchanger system controller can manually or automatically take selected ones of the regenerative heat exchanger modules off-line while the remaining regenerative heat exchanger modules continue to simulate the operation of the rotary regenerative heat exchanger. Also disclosed are a control system and a method for operating a number of independently operable regenerative heat exchanger modules to simulate the operation of a rotary regenerative heat exchanger.

501,610

WO 03/062729 A1